

doors  
collection

**lualdi**<sup>®</sup>

## Index

- 106  
Avenue
- 114  
Boiserie Avenue
- 46  
Compass 55
- 128  
Downtown
- 70  
Drive
- 56  
Filo
- 02  
L16
- 08  
L41
- 14  
L41 Scorrevole
- 86  
Lcd62
- 136  
Lcd87
- 126  
Midtown
- 64  
Outline
- 22  
Rasomuro 55s
- 40  
Rasotouch
- 32  
Rasovetro 55s
- 96  
San Siro
- 76  
Shoin
- 130  
Super
- 134  
Tris
- 122  
Uptown
- 50  
Wall & Door
- 138  
Disegni tecnici /  
Technical drawings
- 160  
Maniglie / Handles
- 164  
Finiture / Finishes

# L16 \_

progettata da Piero Lissoni, L16 è pensata per riduzione. Di spessori, innanzi tutto. Straordinariamente sottile, l'anta battente somiglia a un foglio, una pagina nitida, capace di separare gli ambienti con mano leggera e movimento fluido. Ogni elemento visibile è progettato per scomparire. Quel che si offre allo sguardo è una superficie intatta, ripulita di ogni segno, perfettamente uniforme, vero e proprio elemento architettonico in grado di caratterizzare e definire lo spazio, grazie al risalto di essenze e colori.

Designed by Piero Lissoni, L16 is designed to reduce, especially in thickness. Remarkably thin, the hinged door looks like a sheet, an unblemished page, able to separate spaces with a light touch and fluid motion. Each visible element is designed to disappear.

To the eye it offers a flawless surface, free of any imperfection and perfectly uniform; a true architectural element able to characterize and define the space, thanks to the prominence of woods and colors.







Il coprifilo di L16, qui in laccato rosso lucido, può diventare un pannello ed estendersi intorno alla porta con un effetto boiserie di grande impatto decorativo.

The trim of the L16, here in red gloss lacquer, can become a panel and extend out from around the door providing a boiserie effect of great decorative impact.







## L41 \_

L41 è connotata da un sottile stipite in metallo a valorizzarne il profilo agile.

Progettata da Piero Lissoni ha la particolarità di poter essere realizzata con finiture diverse sui due lati dell'anta, con esiti materici e cromatici interessanti, di originale bellezza.

L41 is distinguished by a thin metal jamb which enhances the light profile. Designed by Piero Lissoni, it is distinguished by the fact that it can be produced with

different finishes for each side of the door, providing interesting combinations of materials and colors and a unique beauty.



Part Of Xmas Gift



Una presenza originale capace di valorizzare lo spazio per la linea sofisticata, creata dal contrasto fra l'effetto di profondità dello stipite in alluminio di gusto high tech e la perfetta complanarità di parete e anta.

Forming an original presence, it enhances the space through its sophisticated line created by the contrast between the depth of the aluminium door jamb and the flushness of the wall and door.







Dettaglio dello stipite in alluminio:  
una pelle high tech che corre lungo  
tutto il perimetro.

Detail of the doorframe in aluminium:  
high-tech leather edges the entire  
length of the perimeter.

## L41 \_ scorrevole

Per uno spazio più fluido L41 scorrevole mette in comunicazione gli ambienti senza la presenza e l'ingombro dell'anta. Il sottile stipite e l'anta a scomparsa nella parete hanno l'effetto di grande pulizia formale.

For a more fluid space the L41 sliding system connects environments without the presence and the dimensions of the leaf.

The in-wall sliding door and its narrow trim create an exceedingly clean-lined appearance.





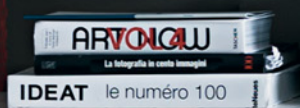
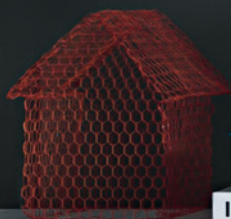



Lo spazio diventa luminoso  
e vivo con l'anta in vetro satinato.

The space becomes bright  
and alive with opal glass door.







Stipite e maniglia in finitura acciaio satinato fanno del metallo il leitmotiv.

Door frame and handle in satin steel finish make metal the leitmotiv.

**L41 scorrevole a scomparsa\_\_21**

## Rasomuro 55s —

è la naturale evoluzione del modello storico Rasomuro, di cui riprende ed esaspera le caratteristiche tecniche che ne hanno decretato il successo. Grazie alle cerniere completamente a scomparsa, al forte spessore e allo stipite invisibile in alluminio, è in grado di integrarsi alla parete con mimetismo perfetto.

This is the natural evolution of the celebrated model Rasomuro, borrowing and embellishing the technical features that were so key to its success. Thanks to the concealed hinging,

the substantial thickness and the invisible aluminium doorjamb, this model is able to assimilate perfectly with the wall.



















Perfettamente complanare e sviluppata a tutta altezza, Rasomuro 55s ha la precisione di un intarsio. La finitura è laccato opaco verde smeraldo. A lato, dettagli di cerniera e stipite.

Full height and perfectly flush, Rasomuro 55s exhibits the precision of a piece of marquetry. The finish is emerald green matte lacquer. Left, details of the hinge and doorjamb.



## Rasovetro 55s —

Rasovetro nasce da Rasomuro e della famiglia ha tutte le caratteristiche, come le cerniere a scomparsa e lo stipite in alluminio. Esteticamente, invece, sviluppa la propria originalità grazie al vetro, materiale pulito per eccellenza, e alle sue prerogative uniche: trasparenza, luminosità, leggerezza.

Rasovetro derives from Rasomuro and shares all its characteristics, such as the concealed hinges and the aluminium jamb. However, it demonstrates its own aesthetic

originality thanks to the glass, the purest of materials, and its unique features of transparency, luminosity and lightness.



Anta in vetro retrolaccato:  
una presenza capace di accendere  
lo spazio di sofisticati riflessi.

Lacquered door: capable  
of lighting up a space with  
sophisticated reflections.







La trasparenza del vetro satinato conferisce allo spazio un'eleganza lieve, naturale.

The transparency of the opal glass lends a light and natural elegance to the space.





9



## Rasotouch —

Rasotouch è il modello più invisibile della famiglia, creato per scomparire completamente nello spazio circostante.

Tocco di perfetta eleganza, la maniglia a scomparsa: un taglio verticale che corre lungo l'anta con la rapidità del più semplice fra i segni: una linea. Design Cairoli & Donzelli.

Rasotouch is the most invisible model of the family, specifically created to disappear completely into the surrounding space.

The recessed handle is a touch of perfect elegance: a vertical cut runs along the door in the simplest of forms - a straight line.

—

—







Finitura in laccato opaco bianco: la porta diventa un elemento architettonico vero e proprio che concorre a rendere lo spazio armonico e omogeneo.

Finished in mat white lacquer: the door becomes a true architectural element which contributes to making the space both uniform and harmonious.



Pratica ed efficiente, la maniglia a scomparsa garantisce una presa facile e gradevole.

Practical and efficient, the recessed handle provides an easy and comfortable grip.



## Compass + Wall & Door \_

perfettamente allineata, dotata di anta pivottante e autochiusura controllata, Compass ha l'aspetto di una quinta ampia e silenziosa, capace di mettere in comunicazione gli spazi con leggerezza. Wall & Door è un sistema che assembla pannelli modulari, ante e porte, pensato come soluzione per razionalizzare, definire e rendere più omogenee le superfici di uno stesso ambiente.

Perfectly aligned and equipped with a self-closing hinged door, Compass can be compared to a large, silent stage curtain, enabling areas to communicate with lightness.

Wall & Door is a system composed of modular panels and doors, created to rationalize, define and harmonize the surfaces of a setting.

















La porta svela un locale studio.  
The door reveals a studio.





La finitura in rovere sbiancato  
è una presenza calda e avvolgente.

The white oak finish is a warm  
and enveloping presence in space.

**Wall & Door\_55**



## Filo \_

perfettamente complanare a stipite e parete, associa alla purezza della superficie una linea slanciata.

Grazie alla battuta rovesciata e all'apertura verso l'interno, ottiene un elegante effetto di continuità con i lati del corridoio. Disponibile nelle nuove eleganti finiture, ha natura versatile e si adatta a muratura, cartongesso e sistemi di pareti mobili.

With the frame and walls perfectly flush, the slim line blends with the purity of the surfaces. The reversed edge and the opening to the interior confer a stylish effect of continuity

with the sides of the corridor. Available in the new elegant finishes, it is versatile and adapts to solid wall, plasterboard and moveable wall systems.

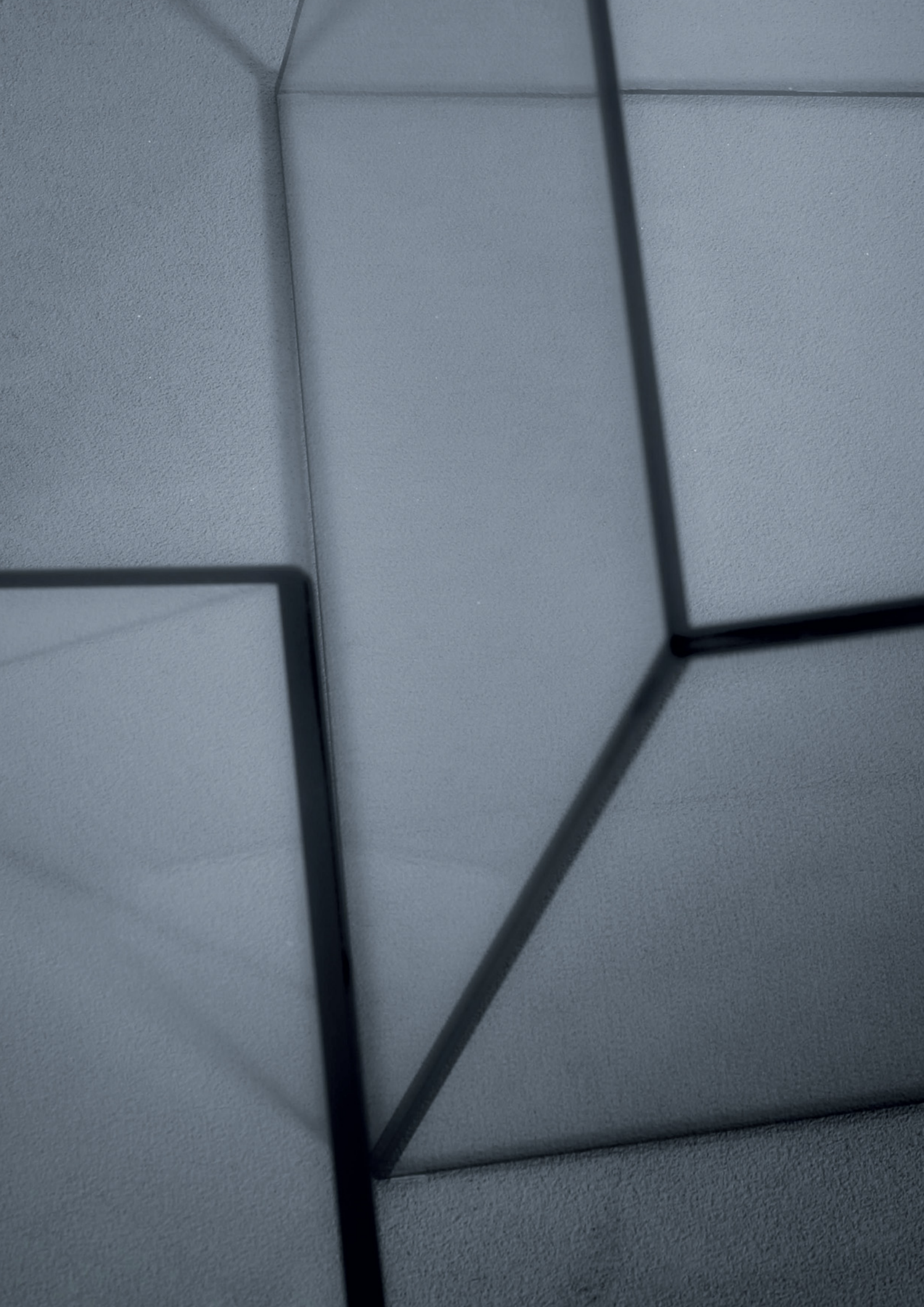

Perfettamente complanare, Filo ottiene un elegante effetto di continuità con le superfici del corridoio.

Perfectly flush, Filo creates an elegant effect of continuity with the surfaces of the corridor.













## Outline —

disegnata da Erik Morvan, offre allo sguardo un volume puro, una superficie tridimensionale, vero e proprio elemento architettonico in grado di definire lo spazio. Fra i vantaggi tecnici: si monta direttamente su parete a lavori finiti, è realizzabile su misura in diverse altezze, ed è disponibile anche in versione con cover, con coprifili sul lato esterno.

Designed by Erik Morvan, the pure volume and three-dimensional surface create a piece of architecture able to lend definition to a space.

It is mounted directly onto the wall and available in a variety of heights. With the cover version the casings are on the outside.

---

---











L'impiallacciatura verticale del rovere tinto grigio si legge come una texture elegantemente naturale.

The vertical veneer of the grey tinted oak creates an elegantly natural texture.

## Drive \_

può leggersi come bella superficie semplicemente appoggiata alla parete, questa anta scorrevole la cui tecnologia, completamente a scomparsa, permette di ottenere effetti di grande leggerezza.

Il binario telescopico, in alluminio ossidato naturale o nero, si applica direttamente a parete.

This sliding door can be seen as a beautiful surface simply laid against the wall. The technology is totally invisible and creates

an effect of extraordinary lightness. The telescopic rail in natural or black anodized aluminium is applied directly to the wall.













# Shoin —

ispirata alle ampie e leggere superfici mobili della casa tradizionale giapponese, Shoin è un sistema di ante scorrevoli e pannelli fissi in vetro, a uno o due binari, progettato per comporre pareti. Le lastre vivono all'interno di un sottile telaio in alluminio, a filo con il vetro sulla facciata esterna della composizione.

Inspired by the light and extensive mobile surfaces of the traditional Japanese house, Shoin is a system of one or two track, glass sliding doors and fixed panels, designed to

create walls. The panels are fixed within a slim aluminium frame, flush with the external side of the composition.











Composizione a due ante scorrevoli,  
con telaio in alluminio e vetro Rain grigio.

Composition with two sliding doors,  
with an aluminium frame and grey  
Rain glass.

**Shoin\_80**











Shoin consente la creazione di veri e propri ambienti, luminose scatole di cristallo che definiscono con leggerezza spazi negli spazi.

Shoin allows the creation of veritable environments, luminous glass boxes to lightly delineate spaces within spaces.

## Lcd62 —

un modello storico riproposto in un'evoluzione che coinvolge tecnica ed estetica. A renderne più flessibili gli usi sono l'anta reversibile, la cerniera a scomparsa e il telaio telescopico, grazie a cui il modello si adatta a diversi spessori di muratura. Le rivisitate proporzioni della cornice e le nuove finiture, accendono la linea classica di note contemporanee.

An historic model that has evolved both technically and aesthetically. The reversible door, the concealed hinge and the adjustable door jamb which adapts to a variety of wall

thicknesses, all allow more flexibility in the range of uses. The revised proportions of the frame and the new finishes lend a contemporary note to the classical line.













La complanarità dello stipite con l'anta danno eleganza e raffinatezza alla parete.

The planarity of the jamb with the door gives elegance and refinement to the wall.



Dettaglio dello stipite esterno, interno  
e della battuta con guarnizione.

Detail of the external and internal  
sides of the doorjamb.









## San Siro —

disegnata da Luigi Caccia Dominioni, recupera le forme della tradizione, interpretandone lo spirito classico in chiave moderna. Il gioco di proporzioni e il disegno delle fasce laterali introducono un elemento di lieve dissonanza in una composizione di grande misura, fatta per abitare con facilità ogni tipo di spazio.

Designed by Luigi Caccia Dominioni, this recuperation of the traditional form interprets the classic spirit with a modern tone. The play of proportions and the design

of the side strips introduce a lightly dissonant element into a composition of great dimension, created to fit easily into any type of space.



Le proporzioni slanciate della porta  
conferiscono un'immagine nuova.

The slender proportions of the door  
give a new image.





La rigidità della maniglia Martina  
è associata al disegno classico  
della porta.

The rigorousness of Martina handle  
is associated with the classic design  
of the door.













Dettaglio della maniglia Lualdi in cromo satinato, su finitura bianco laccato opaco. Lo stipite è dotato di guarnizione in gomma.

Detail of the brushed chrome Lualdi handle on a white matte lacquer finish. The doorjamb is furnished with rubber sealing.

## Avenue —

Robert A.M. Stern abbina la sofisticatezza italiana a un gusto tipicamente americano, per creare una serie di tre porte nello stile tradizionale-moderno caratteristico del suo lavoro.

Le specchiature, dai dettagli vivaci con finitura in legno laccato o naturale, reinterpreta le porte degli appartamenti classici della New York anteguerra. Le porte sono disponibili con specchiatura singola, doppia o tripla. Simmetriche ed equilibrate, con i loro dettagli in puro stile americano, sottili e senza tempo, completano una vasta gamma di interni contemporanei e sono adatte sia per l'arredamento residenziale, che per quello da ufficio e per il settore dell'ospitalità.

Robert A.M. Stern combines Italian sophistication with a distinctly American flavor to create a series of three doors in the modern traditional style characteristic of his work. The mirror paneling with glossy or natural wood finish details reinterprets the doors of a classic New York pre-war apartment.

The doors are available with single, double or triple mirror paneling. Symmetric and balanced, they complement a range of contemporary interiors with subtle, timeless, American details, and are suitable for residential settings as well as hospitality and office applications.





Particolare dello stipite e dell'anta  
in laccato opaco colore terra.

Detail of the jamb and the door  
in matt lacquer Earth color.







Porta laccata opaco bianco  
nella versione con una specchiatura.  
Matte white finish door with one panel.

Porta laccata opaco bianco  
nella versione con due specchiature.  
Matte white finish door with two panels.





Porta laccata opaco bianco nella versione con tre specchiature e inserti in ottone.  
Matte white finish three panel door with brass frames.

Porta laccata bianco opaco nella versione a tre specchiature.  
Matte white finish door with three panels.



# Boiserie Avenue \_

Avenue, di Robert A. M. Stern, offre una riedizione del gusto anglosassone per l'eleganza più classica, studiata su moduli dalle dimensioni non convenzionali.

Avenue, by Robert A. M. Stern, presents a new reading of the Anglo-Saxon taste

---

for a more classical elegance, studied around forms of unconventional dimensions.

---

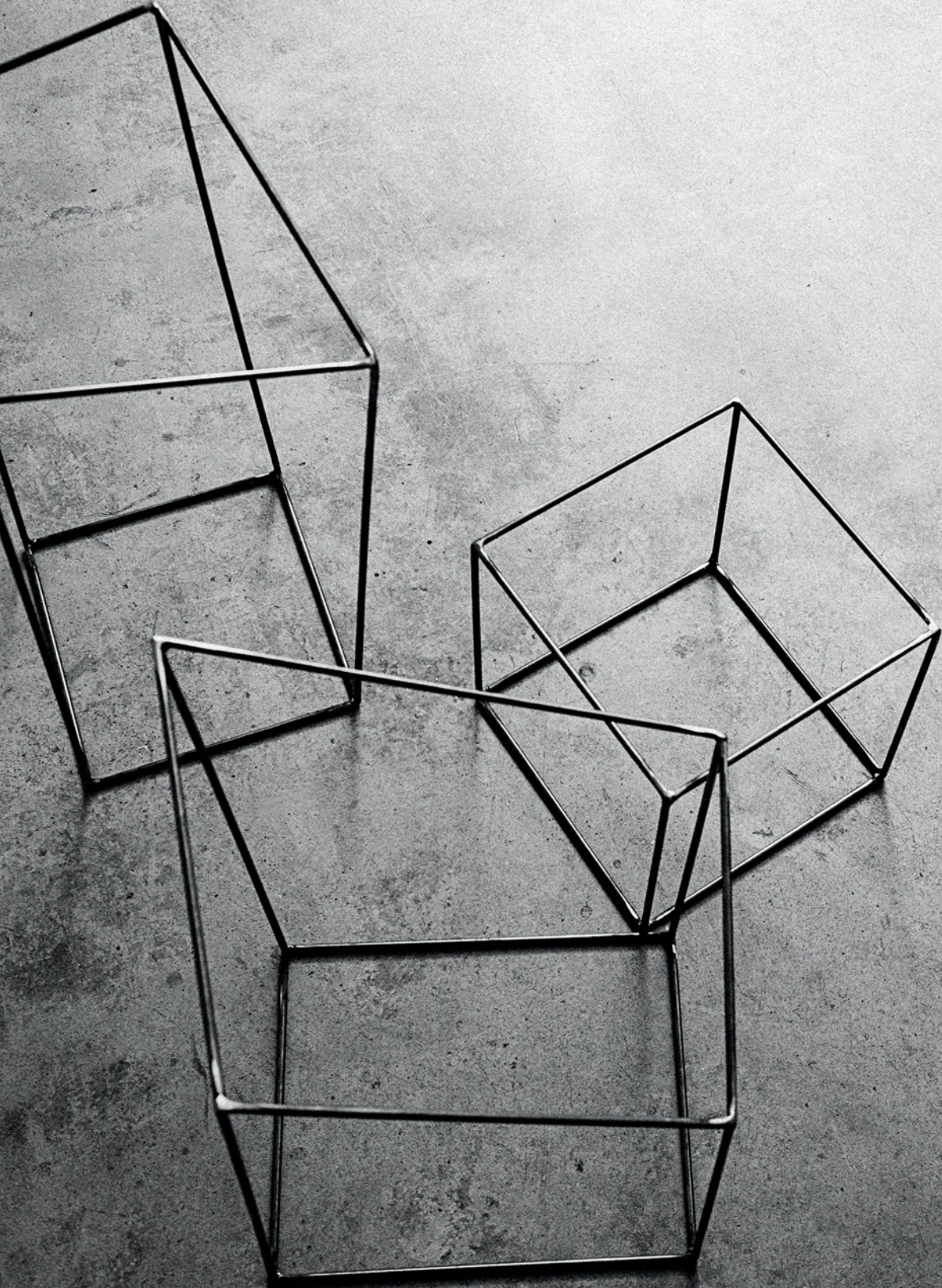













Avenue, di Robert A. M. Stern, offre una riedizione del gusto anglosassone per l'eleganza più classica, studiata su moduli dalle dimensioni non convenzionali.

Avenue, by Robert A. M. Stern, presents a new reading of the Anglo-Saxon taste for a more classical elegance, studied around forms of unconventional dimensions.



# Uptown Midtown Downtown —

Attraverso l'uso di materiali sontuosi David Rockwell crea una porta di squisita fattura ma prettamente moderna. Fatta di pregiato legno di noce, scuro o sbiancato, con telaio in bronzo antico spazzolato, la caratteristica più rilevante di questa porta è la maniglia, una sbarra verticale rivestita in pelle che corre lungo tutta la sua altezza.

Design by David Rockwell

David Rockwell uses sumptuous materials to form a door that is both highly crafted and entirely modern. Made of a rich walnut, either dark or bleached, with a brushed

antique bronze frame, the significant feature of the door is the handle, a vertical bar wrapped in leather, which runs its entire length.  
Design by David Rockwell





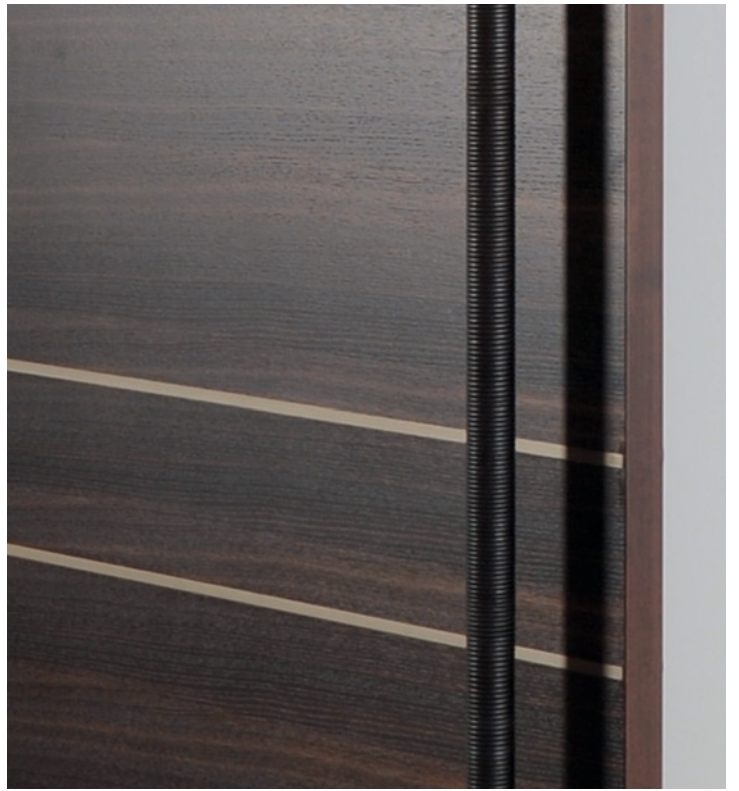

Finitura legno scuro.  
Dark oak veneer.

**UPtown\_\_125**



Finitura in legno sbiancato.  
Stipite in bronzo antico spazzolato.

Bleached walnut.  
Antique bronze finish frame.

**MIDtown\_126**









Finitura laccato opaco bianco.  
Matte white finish.

**DOWNtown\_129**

## Super \_

uno dei modelli storici firmato da Luigi Caccia Dominioni. L'anta, dal bordo arrotondato, è incorniciata dallo stipite in alluminio che ne esalta la superficie ampia e pulita.

One of the classic models designed by Luigi Caccia Dominioni. The door, with its rounded edges, is surrounded by the aluminium frame which exalts the ample and clean surface.

## Tris \_

versatile, adattabile, ideale per pareti mobili e attrezzate. Lo stipite la rende adatta a qualsiasi muro dal punto di vista sia estetico sia tecnico.

Versatile, adaptable and ideal for mobile and accessorised walls. The essential form of the doorjamb makes it suitable for any wall, from both an aesthetic and technical standpoint.

## Lcd87 \_

montata su telaio tradizionale, è la più classica fra le porte, adatta a tutte le situazioni in cui è necessario lo stipite. L'anta, prevista, in un'ampia gamma di finiture è disponibile anche in versione scorrevole.

Mounted on a traditional frame, this is the most classic of the doors and is suitable for all those situations which require a frame. The door is also available in the sliding version.

















# L16

## L16

Porta costruita con materiale composito stabile ed insonorizzato con spessore 16 mm.  
Serratura magnetica.  
Cerniere a perno a scomparsa.  
Guarnizione di battuta.  
Fasce laterali e fascia superiore possono essere fatte a richiesta su misura. Finitura: laccato opaco, lucido o in essenze di serie.

Composite material door leaf  
16 mm thick. Soundproof core.  
Magnetic lockset. Side and top panels can be custom size.  
Pivot concealed hinges.  
Finishes available: matt and glossy lacquer and veneers.



## apertura a spingere / lux - laminated glass door

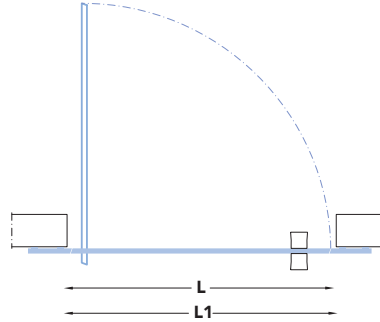

## apertura a tirare / lux - laminated glass door

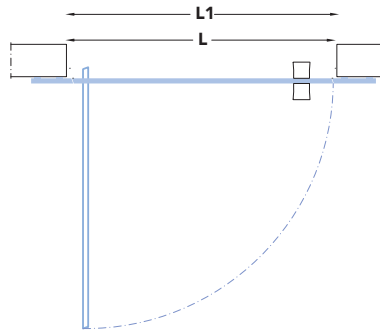

**L**  
Larghezza luce netta  
Opening width  
cm 80 31 1/2"  
cm 90 35 3/8"

**H**  
Altezza luce netta  
Opening height  
cm 210-300 82 5/8"-118 1/4"

**L1 - H1**  
Luce vano da predisporre  
Rough Opening  
cm 82 32 1/4"  
cm 92 36 1/5"

**H1**  
Luce vano da predisporre  
Rough Opening  
cm 211-301 83"-118 1/2"

# L41

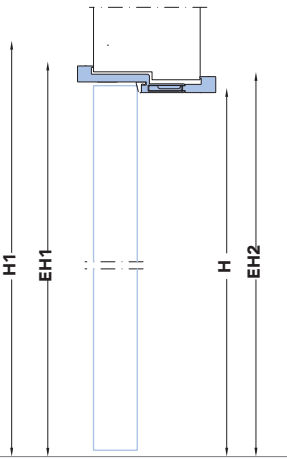
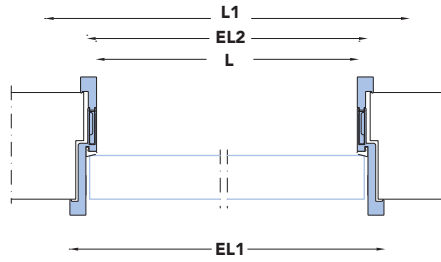

## Versione per muratura / brickwall

**L**  
Larghezza luce netta  
Opening width  
cm 60 23 5/8"  
cm 70 27 1/2"  
cm 80 31 1/2"  
cm 90 35 3/8"

**H**  
Altezza luce netta  
Opening height  
cm 210-300 82 5/8"-118 1/4"

**L1 - H1**  
Ingombro falso telaio  
Subframe dimensions  
cm 70x125 27 1/2" x 84 1/2"  
cm 80x215 21 1/2" x 84 1/2"  
cm 90x215 35 3/8" x 84 1/2"  
cm 100x215 38 3/4" x 84 1/2"

**EL1 - EH1**  
Ingombro max esterno stipite  
Frame max external dimensions  
cm 65x212,5-302,5 25 5/8" x 83 5/8"-119 1/8"  
cm 75x212,5-302,5 29 5/8" x 83 5/8"-119 1/8"  
cm 85x212,5-302,5 33 5/8" x 83 5/8"-119 1/8"  
cm 95x212,5-302,5 37 5/8" x 83 5/8"-119 1/8"

**EL2 - EH2**  
Ingombro stipite  
Frame external dimensions  
cm 63x211,5-301,5 24 7/8" x 83 3/8"-118 3/4"  
cm 73x211,5-301,5 28 5/8" x 83 3/8"-118 3/4"  
cm 83x211,5-301,5 32 3/8" x 83 3/8"-118 3/4"  
cm 93x211,5-301,5 37 1/8" x 83 3/8"-118 3/4"

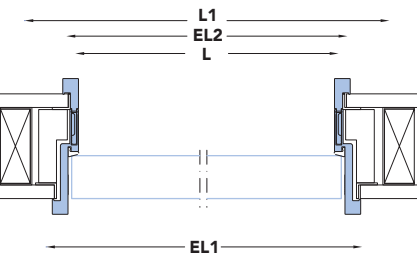

## Versione per cartongesso / drywall

**L**  
Larghezza luce netta  
Opening width  
cm 60 23 5/8"  
cm 70 27 1/2"  
cm 80 31 1/2"  
cm 90 35 3/8"

**H**  
Altezza luce netta  
Opening height  
cm 210-300 82 5/8"-118 1/4"

**L1 - H1**  
Ingombro falso telaio  
Subframe dimensions  
cm 70x125 27 1/2" x 84 1/2"  
cm 80x215 21 1/2" x 84 1/2"  
cm 90x215 35 3/8" x 84 1/2"  
cm 100x215 38 3/4" x 84 1/2"

**EL1 - EH1**  
Ingombro max esterno stipite  
Frame max external dimensions  
cm 65x212,5-302,5 25 5/8" x 83 5/8"-119 1/8"  
cm 75x212,5-302,5 29 5/8" x 83 5/8"-119 1/8"  
cm 85x212,5-302,5 33 5/8" x 83 5/8"-119 1/8"  
cm 95x212,5-302,5 37 5/8" x 83 5/8"-119 1/8"

**EL2 - EH2**  
Ingombro stipite  
Frame external dimensions  
cm 63x211,5-301,5 24 7/8" x 83 3/8"-118 3/4"  
cm 73x211,5-301,5 28 5/8" x 83 3/8"-118 3/4"  
cm 83x211,5-301,5 32 3/4" x 83 3/8"-118 3/4"  
cm 93x211,5-301,5 37 1/2" x 83 3/8"-118 3/4"

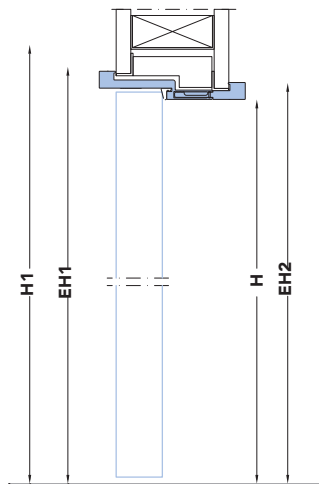

## L41

Porta con battente a struttura tamburata di spessore mm 41 a lavorazione ultimata, con finitura laccato opaco, lucido ed essenze di serie; oppure con battente con telaio perimetrale in alluminio e lastre di vetro. Stipite in alluminio bianco o nero opaco. Guarnizioni di Battuta. Cerniere a scomparsa. Montaggio su falso telaio dedicato.

Swinging door with a hollow core structure; 1 3/4" thick. Factory pre-finish available in matt and polished lacca as well as Lualdi's standard wood veneers. Glass door version is obtained with aluminum surrounding and choice of full size light glass. The frame is available in white or black matt. Included are silencer and concealed hinges. Installation require a subframe

# L41 scorrevole

## L41 scorrevole

L 41 scorrevole a scomparsa.  
Porta con anta a struttura tamburata di spessore mm 41 a lavorazione ultimata con finitura laccato opaco, lucido, essenze oppure con telaio perimetrale in alluminio e lastre di vetro. Stipite in alluminio in diverse finiture. Maniglia ad incasso. Montaggio su cassaporta metallica.

L41 Sliding-pocket 1 3/4 thick  
Swining door with high density Honeycomb structure.  
Door colors available in matt or polished lacquer, and wood veneers. Glass door version is obtained with aluminum surrounding and choice of full size light glass. The frame is available in different finishes. Flush handle. Installation requires a steel frame for stud wall.

versione per muratura / brickwall

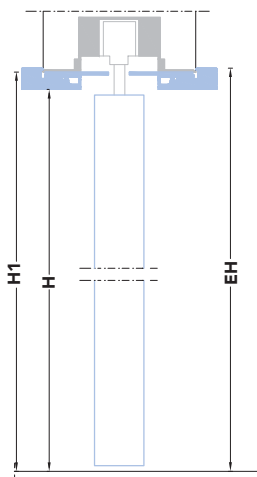

**L**  
Larghezza luce netta  
Opening width  
cm 58 22 13/16"  
cm 68 26 3/4"  
cm 78 30 11/16"  
cm 88 34 5/8"

**L1**  
Dimensione controtelaio  
Subframe dimensions  
cm 60 23 5/8"  
cm 70 27 1/2"  
cm 80 31 1/2"  
cm 90 35 3/8"

**LE**  
ingombro stipite  
Frame dimensions  
cm 61 24"  
cm 71 27 15/16"  
cm 81 31 7/8"  
cm 91 35 13/16"

**HE**  
ingombro stipite  
Frame dimensions  
cm 210,5 - 300,5 82 7/8"-118 5/16"

**H**  
Altezza luce netta  
Opening height  
cm 209 - 299 82 1/4"-117 3/4"

**H1**  
Dimensione controtelaio  
Subframe dimensions  
cm 209 - 299 82 1/4"-117 3/4"



# Raso muro 55s

## Rasomuro 55s

Anta a battente in tamburato, spessore mm 55. Finiture del battente: grezzo con una mano di fondo; laccato opaco e laccato lucido nei colori di serie, essenza di rovere (sbiancato, moka, grigio). Telaio in alluminio; non necessita di falso telaio. Guarnizione di battuta. Cerniera a scomparsa regolabile.

Hollow core hinged door, 55 mm thick. Door panel finish: unfinished with a primer coat, gloss and matte lacquer from standard color range, oak veneer (bleached, moka, grey). Aluminium frame for direct wall installation. Subframe not necessary. Adjustable concealed hinges. Door striker seal.

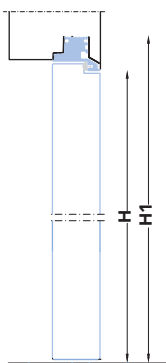
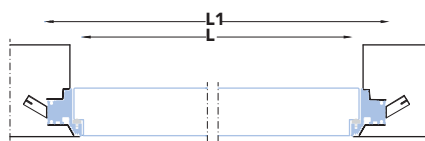

### RM55s spingere per muratura / brickwall push opening

**L**  
Larghezza luce netta  
Opening width  
cm 60 23 5/8"  
cm 70 27 1/2"  
cm 80 31 1/2"  
cm 90 35 3/8"

**H**  
Altezza luce netta  
Opening height  
cm 210 - 300 82 5/8"-118 1/4"

**L1**  
Luce vano da predisporre  
Rough opening  
cm 69 27"  
cm 79 30 7/8"  
cm 89 34 7/8"  
cm 99 38 3/4"

**H1**  
Luce vano da predisporre  
Rough opening  
cm 214,5 - 304,5 84" 5/8"-120"

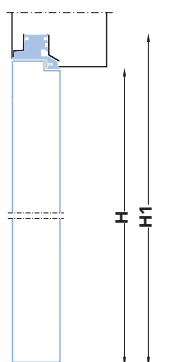
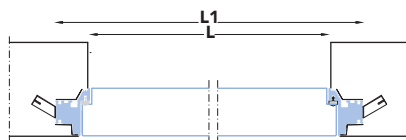

### RM55s tirare per muratura / brickwall pull opening

**L**  
Larghezza luce netta  
Opening width  
cm 60 23 5/8"  
cm 70 27 1/2"  
cm 80 31 1/2"  
cm 90 35 3/8"

**H**  
Altezza luce netta  
Opening height  
cm 210 - 300 82 5/8"-118 1/4"

**L1**  
Luce vano da predisporre  
Rough opening  
cm 69 27"  
cm 79 30 7/8"  
cm 89 34 7/8"  
cm 99 38 3/4"

**H1**  
Luce vano da predisporre  
Rough opening  
cm 214,5 - 304,5 84" 5/8"-120"

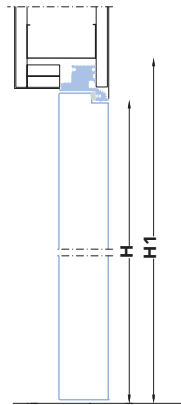
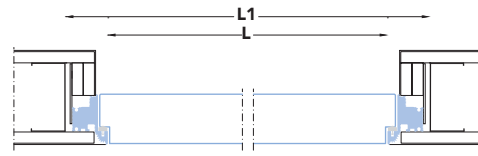

**RM55s spingere per cartongesso / drywall push opening**

**L**

Larghezza luce netta  
Opening width  
cm 60 23 5/8"  
cm 70 27 1/2"  
cm 80 31 1/2"  
cm 90 35 3/8"

**H**

Altezza luce netta  
Opening height  
cm 210 - 300 82 5/8"-118 1/4"

**L1**

Luce vano da predisporre  
Rough opening  
cm 69,5 27 3/8"  
cm 79,5 31 3/8"  
cm 89,5 35 1/8"  
cm 99,5 39 1/4"

**H1**

Luce vano da predisporre  
Rough opening  
cm 214,5 - 304,5 84 5/8"-120"

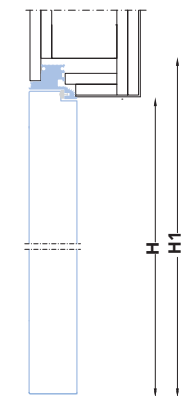
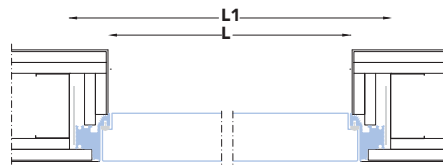

**RM55s tirare per cartongesso / drywall pull opening**

**L**

Larghezza luce netta  
Opening width  
cm 60 23 5/8"  
cm 70 27 1/2"  
cm 80 31 1/2"  
cm 90 35 3/8"

**H**

Altezza luce netta  
Opening height  
cm 210 - 300 82 5/8"-118 1/4"

**L1**

Luce vano da predisporre  
Rough opening  
cm 69,5 27 3/8"  
cm 79,5 31 3/8"  
cm 89,5 35 1/8"  
cm 99,5 39 1/4"

**H1**

Luce vano da predisporre  
Rough opening  
cm 214,5 - 304,5 84 5/8"-120"



# Raso vetro 55s

## Rasovetro 55s

Battente spessore mm 55 con telaio perimetrale in alluminio e lastre di vetro temperato spessore mm 4 da entrambi i lati. Vetri finiture di serie. Telaio in alluminio.

Swinging leaf door, 55 mm thick, composed by aluminum surrounding and 4 mm tempered glass sheets thick on both sides. Available Glass finishes as per Lualdi's chart. Aluminum frame.



**L**  
Larghezza luce netta  
*Opening width*  
cm 60 23 <sup>5</sup>/<sub>8</sub>"  
cm 70 27 <sup>1</sup>/<sub>2</sub>"  
cm 80 31 <sup>1</sup>/<sub>2</sub>"  
cm 90 35 <sup>3</sup>/<sub>8</sub>"

**H**  
Altezza luce netta  
*Opening height*  
cm 210 - 300 82 <sup>5</sup>/<sub>8</sub>"-118 <sup>1</sup>/<sub>4</sub>"

# Raso touch



## Rasotouch

design Cairoli & Donzelli

Battente spessore mm 55 con maniglia a scomparsa, l'apertura è ottenuta con pressione della fascia verticale. Battente laccato opaco, lucido o in essenza di serie. Fascia a pressione sempre laccata colore opaco. Telaio in alluminio.

Swinging wood door, 55 mm thick, with a concealed incorporated handle. The handle operates by pressing the vertical band. Factory pre-finish available in matt and polished lacca as well as Lualdi's standard wood veneers. Handle's vertical band always lacquered in opaque color. Aluminum frame.

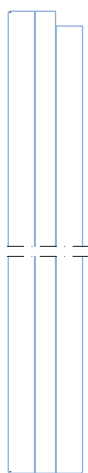

### L

Larghezza luce netta

Opening width

cm 60 23 5/8"

cm 70 27 1/2"

cm 80 31 1/2"

cm 90 35 3/8"

### H

Altezza luce netta

Opening height

cm 210 - 300 82 5/8"-118 1/4"

# Compass 55

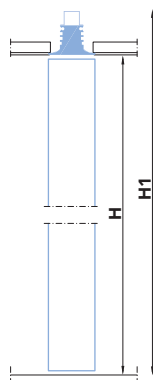
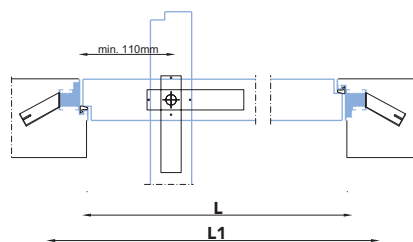

## versione per muratura / brickwall

**L**  
Larghezza luce netta  
Opening width  
cm 60 23 5/8"  
cm 70 27 1/2"  
cm 80 31 1/2"  
cm 90 35 3/8"

**H**  
Altezza luce netta  
Opening height  
cm 210 - 300 82 5/8"-118 1/4"

**L1 - H1**  
Luce vano da predisporre  
Rough opening  
cm 69x214,5-304,5 28" x84 5/8"-120"  
cm 79x214,5-304,5 31 7/8"x84 5/8"-120"  
cm 89x214,5-304,5 35 7/8"x84 5/8"-120"  
cm 99x214,5-304,5 39 3/4"x84 5/8"-120"

## Compass 55

Porta a battente con anta a struttura tamburata di spessore mm 55. Finitura del battente: grezzo con mano di fondo, laccato lucido o opaco nei colori di serie, impiallacciato verticalmente in essenze di serie. Impiallacciatura orizzontale solo su richiesta. Telaio-stipite in alluminio anodizzato preassemblato da murare. Non necessita di falso telaio. Guarnizioni di battuta. Cerniere a scomparsa.

Hollow core hinged door, 55 mm thick. Door panel: unfinished with a primer coat, gloss and matte lacquer from standard color range, vertically aligned veneers from standard range. Horizontal veneer on request. Jamb and door frame in pre-assembled anodized aluminium for direct wall installation. Subframe not necessary. Door striker seal. Concealed hinges.

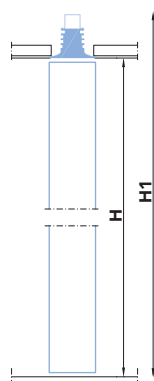
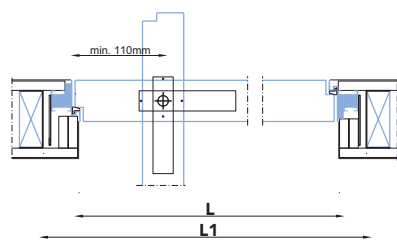

## versione per cartongesso / drywall

**L**  
Larghezza luce netta  
Opening width  
cm 60 23 5/8"  
cm 70 27 1/2"  
cm 80 31 1/2"  
cm 90 35 3/8"

**H**  
Altezza luce netta  
Opening height  
cm 210 - 300 82 5/8"-118 1/4"

**L1 - H1**  
Luce vano da predisporre  
Rough opening  
cm 69x214,5-304,5 28" x84 5/8"-120"  
cm 79x214,5-304,5 31 7/8"x84 5/8"-120"  
cm 89x214,5-304,5 35 7/8"x84 5/8"-120"  
cm 99x214,5-304,5 39 3/4"x84 5/8"-120"

# Wall & Door

## Wall & Door

Sistema costituito da pannelli fissi ed apribili realizzati su misura, entrambi prevedono una struttura tamburata di spessore mm 55, initura laccato lucido o opaco o impiallacciata verticalmente in essenze di serie. Impiallacciatura orizzontale solo su richiesta. Completa di ferramenta, cerniere a scomparsa.

Wall system made of custom sizes fixed and swing opening panels. Hollow core construction 55 mm thick. Finishes available: vertical wood veneer, matt and glossy lacquer. Horizontal veneer only upon request.

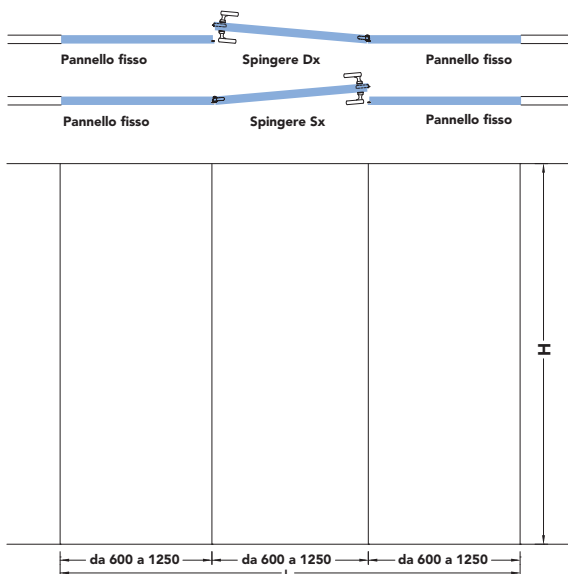

### wall & door a battente / swing door

**L**  
Larghezza pannello fisso  
Width fixed panel  
cm 10 - 125 3<sup>15</sup>/<sub>16</sub>" - 49<sup>1</sup>/<sub>4</sub>"

**H**  
Altezza max pannello  
Max panel height  
max cm 300 118<sup>1</sup>/<sub>4</sub>"

Larghezza pannello apribile  
Width opening panel  
cm 60 - 125 23<sup>5</sup>/<sub>8</sub>" - 49<sup>1</sup>/<sub>4</sub>"

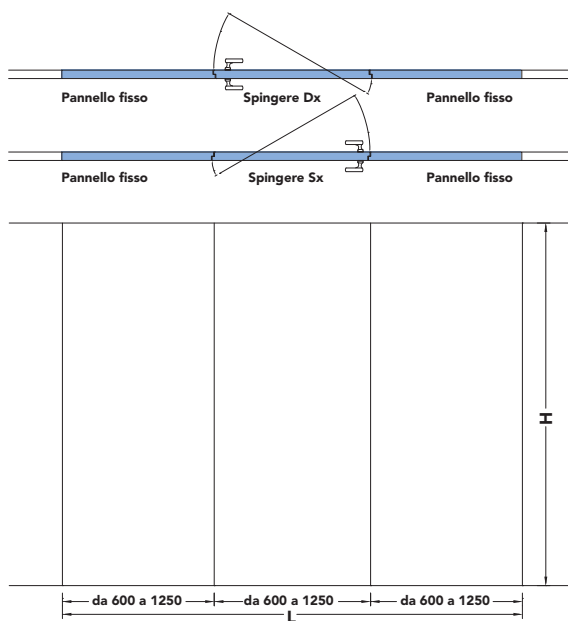

### wall & door compass / offset door

**L**  
Larghezza pannello fisso  
Width fixed panel  
cm 10 - 125 3<sup>15</sup>/<sub>16</sub>" - 49<sup>1</sup>/<sub>4</sub>"

**H**  
Altezza max pannello  
Max panel height  
max cm 300 118<sup>1</sup>/<sub>4</sub>"

Larghezza pannello apribile  
Width opening panel  
cm 60 - 125 23<sup>5</sup>/<sub>8</sub>" - 49<sup>1</sup>/<sub>4</sub>"

# Filo s-t

## Filo s-t

Porta a battente in tamburato, spessore mm 55. Battente, stipite e coprifili in laccato opaco nei colori di serie e in essenze. Versione Lux con vetro opalino. Sistema telescopico dello stipite da cm 10 a cm 12. Guarnizione di battuta. Cerniere a scomparsa. Montaggio su falsi telai tradizionali in legno.

Hollow-core hinge door, thickness 55 mm. Door panel, jamb and casing in matte lacquer in standard colours and in wood with opal glass in the Lux version.

Door jamb adjustable from 10 cm to 12 cm. Door striker seal. Concealed hinges. Mounted on traditional wood subframe.

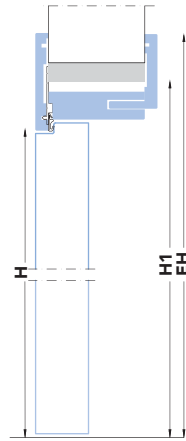
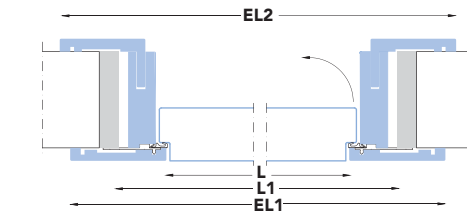

### filo s apertura a spingere / push opening

**H**  
Altezza luce netta  
Opening height  
cm 210 - 300 82 5/8"-118 1/4"

**H1**  
Altezza falso telaio  
Subframe height  
cm 215 - 305 84 1/2"-120

**L**  
Larghezza luce netta  
Opening width  
cm 60 23 5/8"  
cm 70 27 1/2"  
cm 80 31 1/2"  
cm 90 35 3/8"

**L1**  
Larghezza falso telaio  
Subframe width  
cm 70 27 1/2"  
cm 80 31 1/2"  
cm 90 35 3/8"  
cm 100 38 3/4"

**EH**  
Ingombro esterno max  
Max external dimensions  
cm 220 - 310 86 7/8"-122

**EL1**  
Ingombro esterno  
External dimensions  
cm 80 31 1/2"  
cm 90 35 3/8"  
cm 100 38 3/4"  
cm 110 43 1/4"

**EL2**  
Ingombro esterno max  
Max external dimensions  
cm 82,2 32 1/8"  
cm 92,2 36  
cm 102,2 40  
cm 102,2 43

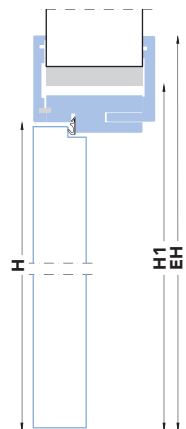
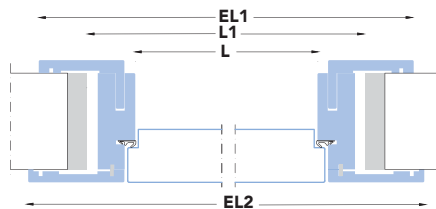

### filo t apertura a tirare / pull opening

**L**  
Larghezza luce netta  
Opening width  
cm 60 23 5/8"  
cm 70 27 1/2"  
cm 80 31 1/2"  
cm 90 35 3/8"

**L1**  
Larghezza falso telaio  
Subframe width  
cm 70 27 1/2"  
cm 80 31 1/2"  
cm 90 35 3/8"  
cm 100 38 3/4"

**H**  
Altezza luce netta  
Opening height  
cm 210 - 300 82 5/8"-118 1/4"

**H1**  
Altezza falso telaio  
Subframe height  
cm 215 - 305 84 1/2"-120

**EH**  
Ingombro esterno max  
Max external dimensions  
cm 220 - 310 86 7/8"-122

**EL1**  
Ingombro esterno  
External dimensions  
cm 80 31 1/2"  
cm 90 35 3/8"  
cm 100 38 3/4"  
cm 110 43 1/4"

**EL2**  
Ingombro esterno max  
Max external dimensions  
cm 82,2 32 1/8"  
cm 92,2 36  
cm 102,2 40  
cm 102,2 43

# Outline

## Outline

Porta a battente in tamburato.  
Bordi a sezione squadrata.  
Battente in rovere (sbiancato, moka, grigio), ebano, teak; laccato lucido e laccato opaco nei colori di serie. Telaio in alluminio per installazione diretta sulla parete.  
Cerniere pivotanti in acciaio.  
Guarnizione di battuta. Montaggio su vano muro presquadrato.  
Serratura orizzontale.

Hollow core hinged door.  
Squared edges. Veneered in oak (bleached, moka, dark grey), ebony, teak, gloss and matte lacquer from standard color range.  
Aluminium frame for direct wall installation. Pivoting steel hinges.  
Horizontal lock. Installation on pre-squared wall. Door striker seal.

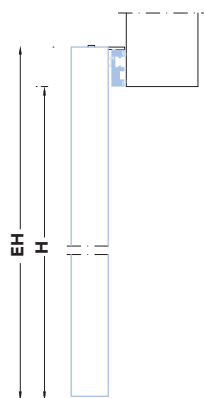
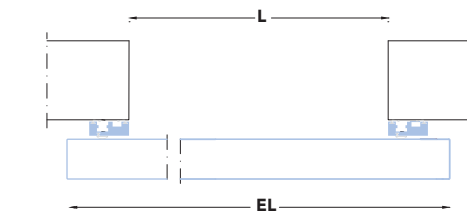

**L**  
Larghezza luce netta  
Opening width  
cm 60 23 5/8"  
cm 70 27 1/2"  
cm 80 31 1/2"  
cm 90 35 3/8"

**H**  
Altezza luce netta  
Opening height  
cm 210 - 300 82 3/8"-118 1/4"

**EL - EH**  
Ingombro anta  
Door dimensions  
cm 74x214,8-304,8 29 1/8"x84 5/8"-120 1/8"  
cm 84x214,8-304,8 33 1/8"x84 5/8"-120 1/8"  
cm 94x214,8-304,8 37" x84 5/8"-120 1/8"  
cm 104x214,8-304,8 41" x84 5/8"-120 1/8"

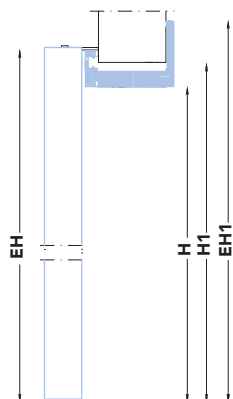
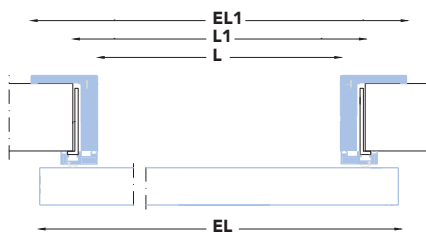

### outline con cover / with cover

**L**  
Larghezza luce netta  
Opening width  
cm 60 23 5/8"  
cm 70 27 1/2"  
cm 80 31 1/2"  
cm 90 35 3/8"

**L1 - H1**  
Misura al grezzo  
rough opening  
cm 66x213-303 26" x83 7/8"-119 3/8"  
cm 76x213-303 29 7/8"x83 7/8"-119 3/8"  
cm 86x213-213 33 1/8"x83 7/8"-119 3/8"  
cm 96x213-303 37 3/4"x83 7/8"-119 3/8"

**H**  
Altezza luce netta  
Opening height  
cm 210 - 300 82 3/8"-118 1/4"

**EL - EH**  
Ingombro anta  
Door dimensions  
cm 74x214,8-304,8 29 1/8"x84 5/8"-120 1/8"  
cm 84x214,8-304,8 33 1/8"x84 5/8"-120 1/8"  
cm 94x214,8-304,8 37" x84 5/8"-120 1/8"  
cm 104x214,8-304,8 41" x84 5/8"-120 1/8"

**EL - EH**  
Ingombro cover  
Cover dimensions  
cm 76x218-308 29 7/8" x85 7/8"-121 3/8"  
cm 86x218-308 33 7/8" x85 7/8"-121 3/8"  
cm 96x218-308 37 3/4" x85 7/8"-121 3/8"  
cm 106x218-308 41 3/4" x85 7/8"-121 3/8"

# Drive

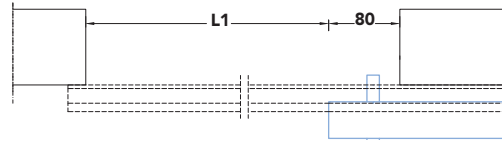
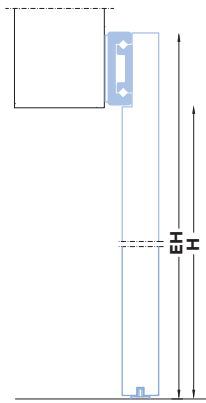

## Drive

Porta scorrevole in tamburato.  
Bordi a sezione quadrata.  
Finiture dell'anta: essenza di rovere (sbiancato, moka, grigio), ebano, teak o laccato lucido e opaco nei colori di serie. Binario telescopico in alluminio per installazione diretta sulla parete. Finiture del binario: alluminio satinato o anodizzato nero. Montaggio su muro presquadrato.

Hollow core sliding door.  
Squared edges. Finishes: oak (bleached, moka and dark grey), ebony, teak, polished and matte enamelled in range colours  
Aluminum telescopic track for direct wall installation.  
Track finishes: aluminium inox and black anodized aluminium.  
Installation on pre-squared wall.

versione per muratura / brickwall

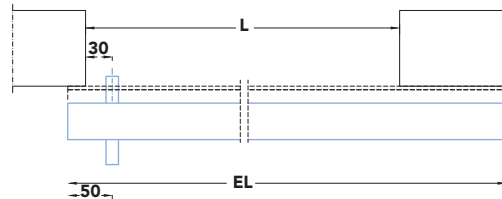
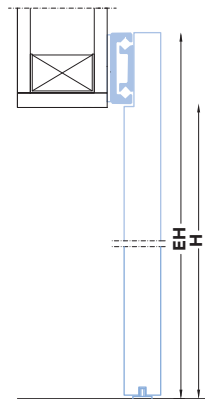

versione per cartongesso / drywall

**L**  
Larghezza vano  
Opening width  
cm 70 27 1/2"  
cm 80 31 1/2"  
cm 90 35 3/8"

**EH**  
Ingombro esterno max  
Max external dimensions  
cm 84x218,4-308,4 33" x85 5/8"-121 1/2"  
cm 94x218,4-308,4 37" x85 5/8"-121 1/2"  
cm 104x218,4-308,4 407/8" x85 5/8"-121 1/2"

**L1**  
Luce netta passaggio  
Net opening  
cm 62 24 3/8"  
cm 72 28 1/8"  
cm 82 32"

**H**  
Altezza luce netta  
Opening height  
cm 210-300 82 5/8"-118 1/4"

# Shoin

## Shoin

Sistema di ante fisse e scorrevoli con spessore mm 50 realizzate su misura. Ante in vetro di sicurezza spessore mm 6 finiture di serie. Telaio di contenimento in alluminio finiture di serie. Binario ad una o due vie, sistema di freno decelerante. Meccanismo di regolazione in altezza nascosto nel carrello del binario.

50 mm thickness sliding door with ceiling tracks. Laminated glass door panel, 6 mm thick. Glass finishes: transparent, opal, bronzed, grey, rain. Aluminium frame. Single or double rail. Height adjustment mechanism hidden in track.

### binario singolo / single track

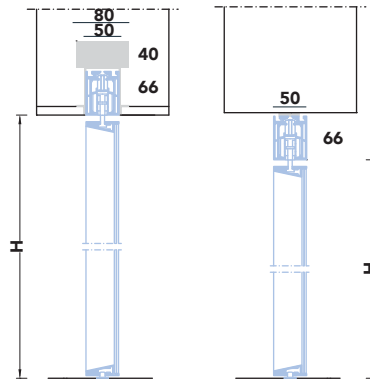

### anta singola esterno muro / external single door leaf

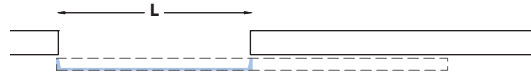

### due ante esterno muro / external double door leaves

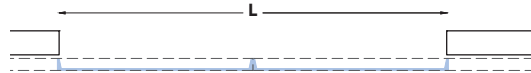

### binario doppio / double track

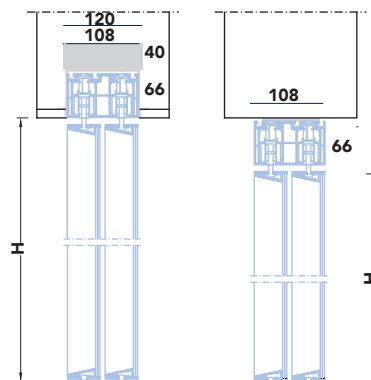

### due ante interno muro / internal double door leaves



### quattro ante interno muro / internal four door leaves



**L**  
Max  
mm 1200 47 1/4"

**H**  
Max  
mm 300 11,8 1/4"



# Lcd 62

## Lcd62

Porta a battente in tamburato, spessore mm 41. Battente, stipite e coprifili in laccato opaco nei colori di serie, essenza di rovere (sbiancato, moka, grigio).

Versione Lux con vetro opalino  
Sistema telescopico dello stipite: da cm 9,5 a 12 e da cm 12,5 a 15.  
Guarnizione di battuta.  
Reversibilità del senso di apertura.  
Cerniere a scomparsa. Montaggio su falsi telai tradizionali in legno.  
Disponibile anche in versione scorrevole esterna o a scomparsa.

Hollow-core hinge door, thickness 41 mm. Door panel, jamb and casing in matte lacquer in standard colours and in oak (bleached, mocha, grey).  
Lux version with opal glass.  
Door jamb adjustable from 9.5 to 12 cm and from 12.5 to 15 cm. Door striker seal.  
Reversible opening. Concealed hinges. Mounted on traditional wood subframe. Also available in pocket and surface mounted sliding versions.

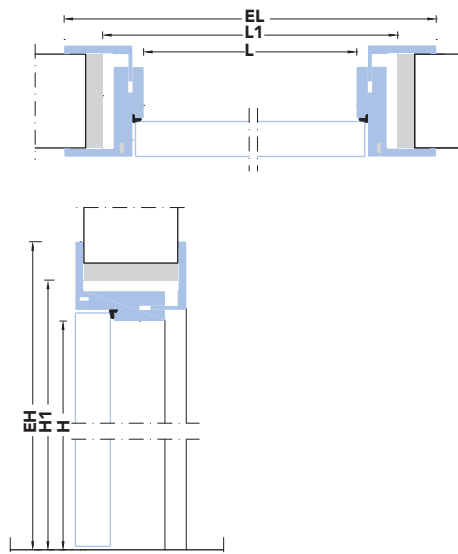

### L

Larghezza luce netta  
Opening width  
cm 60 23 5/8"  
cm 70 27 1/2"  
cm 80 31 3/8"  
cm 90 35 3/8"

### L1

Larghezza falso telaio  
Subframe width  
cm 70 27  
cm 80 30 7/8"  
cm 90 34 7/8"  
cm 100 38 3/4"

### H

Altezza luce netta  
Opening height  
cm 210-300 82 5/8"-118 1/4"

### H1

Larghezza falso telaio  
Subframe width  
cm 215-305 84 1/2"-120"

### EH

Ingombro esterno  
External dimensions  
cm 219-309 86 1/4"-121 3/4"

### EL

Ingombro esterno max  
Max external dimensions  
cm 78 30 3/4"  
cm 88 30 5/8"  
cm 98 34 5/8"  
cm 108 38 1/2"

# San Siro

## San Siro

Porta a battente in tamburato, spessore mm 41, con specchiature incassate. Battente e stipite laccato opaco nei colori di serie. Sistema telescopico dello stipite da cm 9,5 a cm 12 e da cm 12,5 a cm 15. Guarnizione di battuta. Reversibilità del senso di apertura. Cerniere a scomparsa. Montaggio su falsi telai tradizionali in legno. Disponibile anche in versione scorrevole esterna o a scomparsa.

Hollow core hinged door, 41 mm thick, with recessed symmetric panels. Door panel and jamb in matte finish from standard color range. Telescopic doorjamb: from 9.5 to 12 cm and from 12.5 to 15 cm. Door striker seal. Reversible opening direction. Concealed hinges. Mounted on traditional wooden subframe. Pocket or external sliding versions also available.

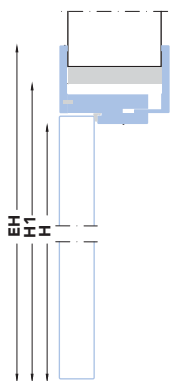
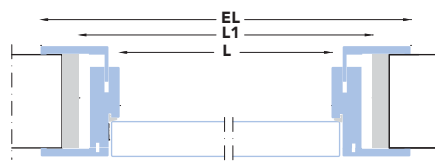

### L

Larghezza luce netta  
Opening width  
cm 60 23 5/8"  
cm 70 27 1/2"  
cm 80 31 3/8"  
cm 90 35 3/8"

### L1

Larghezza falso telaio  
Subframe width  
cm 70 27  
cm 80 30 7/8"  
cm 90 34 7/8"  
cm 100 38 3/4"

### H

Altezza luce netta  
Opening height  
cm 210 82 5/8"

### H1

Altezza falso telaio  
Subframe height  
cm 215 84 1/2"

### EH

Ingombro esterno  
External dimensions  
cm 219 86 1/4"

### EL

Ingombro esterno max  
Max external dimensions  
cm 78 30 3/4"  
cm 88 34 5/8"  
cm 98 38 5/8"  
cm 108 42 1/2"

# Avenue

## Avenue

design Robert A.M. Stern

Porta a battente tamburato spessore 41 mm con specchiature incassate a uno, due o tre riquadri. Battente e stipite laccati opaco nei colori di serie, stipite telescopico, guarnizioni di battuta e cerniere a scomparsa.

Hollow core swing door 41 mm thick with one, two or three recessed panels. Door panel and frame in matte finish in Lualdi's range of colors, telescopic door jamb, rubber gasket, concealed hinges.

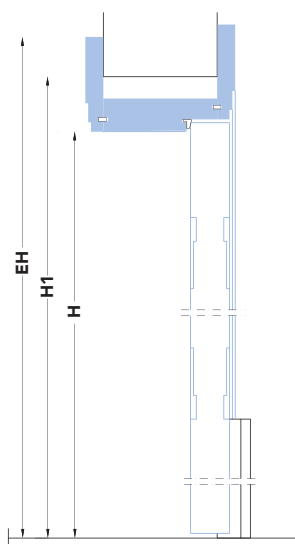
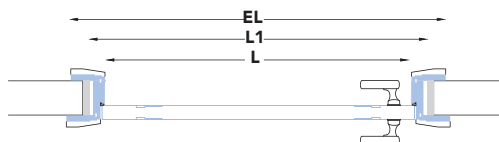

**L**  
Larghezza luce netta  
Opening width  
cm 60 23 <sup>5</sup>/<sub>8</sub>"  
cm 70 27 <sup>1</sup>/<sub>2</sub>"  
cm 80 31 <sup>1</sup>/<sub>2</sub>"  
cm 90 35 <sup>3</sup>/<sub>8</sub>"

**L1**  
Larghezza falso telaio  
Subframe width  
cm 70 27  
cm 80 30 <sup>7</sup>/<sub>8</sub>"  
cm 90 34 <sup>7</sup>/<sub>8</sub>"  
cm 100 38 <sup>3</sup>/<sub>4</sub>"

**H**  
Altezza luce netta  
Opening height  
cm 210 82 <sup>5</sup>/<sub>8</sub>"

**H1**  
Larghezza falso telaio  
Subframe width  
cm 215 84 <sup>1</sup>/<sub>2</sub>"

**EH**  
Ingombro esterno  
External dimensions  
cm 223,0 - 311,3 87 <sup>13</sup>/<sub>16</sub>" - 123 <sup>1</sup>/<sub>4</sub>"

**EL**  
Ingombro esterno max  
Max external dimensions  
cm 82,6 32 <sup>1</sup>/<sub>2</sub>"  
cm 92,6 36 <sup>7</sup>/<sub>16</sub>"  
cm 102,6 40 <sup>3</sup>/<sub>8</sub>"  
cm 112,6 44 <sup>5</sup>/<sub>16</sub>"

# Boiserie Avenue

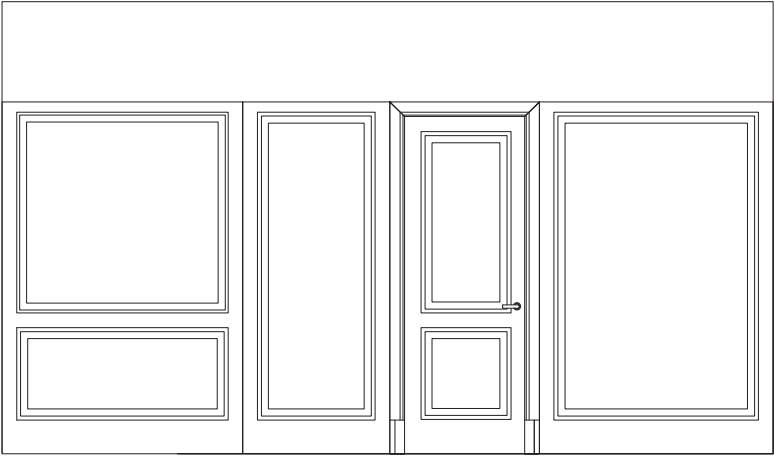
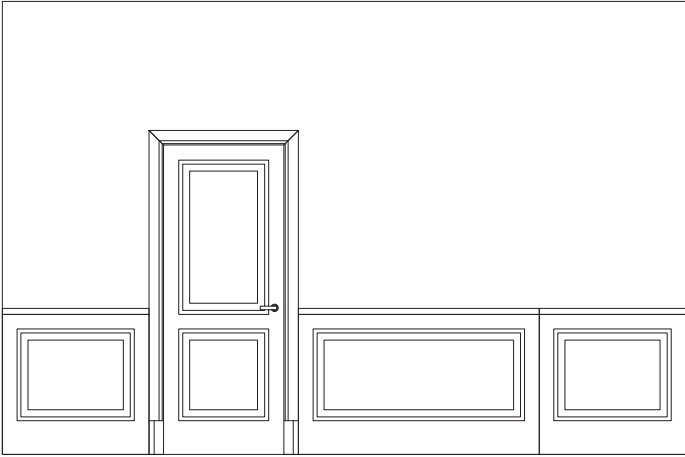

# Uptown Midtown Downtown

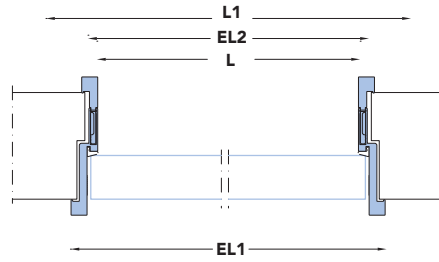

## Uptown Midtown Downtown design David Rockwell

Porta a battente tamburato spessore 41 mm. Battente con inserti in metallo, finitura: impiallacciata in orizzontale in rovere scuro, rovere chiaro e laccato lucido, stipite telescopico in alluminio, cerniera a scomparsa e guarnizione di battuta.

Hollow core swing door 41 mm thick. Door panel with metal inlays, finishes: horizontal dark oak/walnut veneer or glossy lacquer in all Lualdi's colors range, telescopic aluminum frame, rubber gasket, concealed hinges.

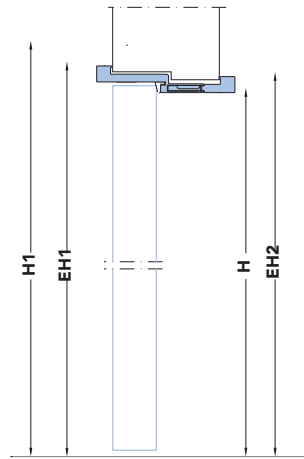

### Versione per muratura / brickwall

**L**  
Larghezza luce netta  
Opening width  
cm 60 23 5/8"  
cm 70 27 1/2"  
cm 80 31 1/2"  
cm 90 35 3/8"

**H**  
Altezza luce netta  
Opening height  
cm 210 - 300 82 5/8"-118 1/4"

**L1 - H1**  
Ingombro falso telaio  
Subframe dimensions  
cm 70x125 27 1/2" x 84 1/2"  
cm 80x215 21 1/2" x 84 1/2"  
cm 90x215 35 3/8" x 84 1/2"  
cm 100x215 38 3/4" x 84 1/2"

**EL1 - EH1**  
Ingombro max esterno stipite  
Frame max external dimensions  
cm 65x212,5-302,5 25 5/8" x 83 5/8"-119 1/8"  
cm 75x212,5-302,5 29 5/8" x 83 5/8"-119 1/8"  
cm 85x212,5-302,5 33 5/8" x 83 5/8"-119 1/8"  
cm 95x212,5-302,5 37 5/8" x 83 5/8"-119 1/8"

**EL2 - EH2**  
Ingombro stipite  
Frame external dimensions  
cm 63x211,5-301,5 24 7/8"x83 3/8"-118 3/4"  
cm 73x211,5-301,5 28 5/8"x83 3/8"-118 3/4"  
cm 83x211,5-301,5 32 3/4"x83 3/8"-118 3/4"  
cm 93x211,5-301,5 37 1/2"x83 3/8"-118 3/4"

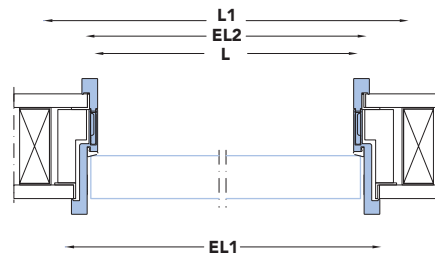

### Versione per cartongesso / drywall

**L**  
Larghezza luce netta  
Opening width  
cm 60 23 5/8"  
cm 70 27 1/2"  
cm 80 31 1/2"  
cm 90 35 3/8"

**H**  
Altezza luce netta  
Opening height  
cm 210 - 300 82 5/8"-118 1/4"

**L1 - H1**  
Ingombro falso telaio  
Subframe dimensions  
cm 70x125 27 1/2" x 84 1/2"  
cm 80x215 21 1/2" x 84 1/2"  
cm 90x215 35 3/8" x 84 1/2"  
cm 100x215 38 3/4" x 84 1/2"

**EL1 - EH1**  
Ingombro max esterno stipite  
Frame max external dimensions  
cm 65x212,5-302,5 25 5/8" x 83 5/8"-119 1/8"  
cm 75x212,5-302,5 29 5/8" x 83 5/8"-119 1/8"  
cm 85x212,5-302,5 33 5/8" x 83 5/8"-119 1/8"  
cm 95x212,5-302,5 37 5/8" x 83 5/8"-119 1/8"

**EL2 - EH2**  
Ingombro stipite  
Frame external dimensions  
cm 63x211,5-301,5 24 7/8" x 83 3/8"-118 3/4"  
cm 73x211,5-301,5 28 5/8" x 83 3/8"-118 3/4"  
cm 83x211,5-301,5 32 3/4" x 83 3/8"-118 3/4"  
cm 93x211,5-301,5 37 1/2" x 83 3/8"-118 3/4"

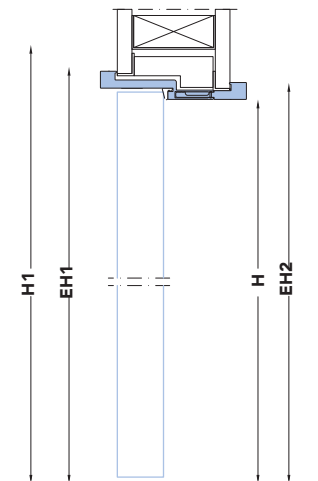

# Super

## Super

Porta a battente in tamburato, spessore mm 41. Bordi a sezione arrotondata. Battente laccato lucido al poliestere nei colori di serie; laccato opaco e in essenza di rovere (sbiancato, moka, grigio), e radiche su richiesta. Versione Lux con vetro opalino. Stipite in alluminio laccato opaco. Spessore stipite cm 10, 11 e 12,5. Feltrino di battuta. Reversibilità del senso di apertura. Cerniere a scomparsa. Montaggio su falsi telai in lamiera verniciata.

Hollow core hinged door, 41 mm thick. Border with rounded edges. Gloss polyester lacquer door panel available in standard range colours, oak veneer (bleached, mocha, grey), briar-root upon request. Lux version features opal glass. Jamb in matte lacquered aluminum. Jamb thickness of 10, 11 and 12.5 cm. Felt protector. Reversible opening direction. Concealed hinges. Mounted on subframe with painted sheet metal.

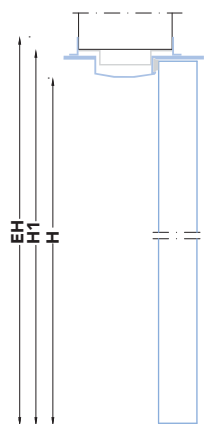
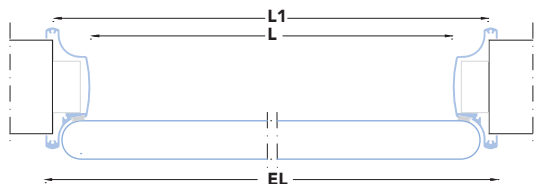

### L

Larghezza luce netta

Opening width

cm 60 23 5/8"

cm 70 27 1/2"

cm 80 31 1/2"

cm 90 35 1/2"

### L1

Larghezza falso telaio

Subframe width

cm 68 26 3/4"

cm 78 30 3/4"

cm 88 34 5/8"

cm 98 38 3/4"

### H

Altezza luce netta

Opening height

cm 210-300 82 5/8"-118 1/4"

### H1

Altezza falso telaio

Subframe height

cm 213-303 83 7/8"-119 3/8"

### EL - EH

Ingombro esterno max

Max external dimensions

cm 70x214,4-304,4 27 1/2"x84 1/2"-120"

cm 80x214,4-304,4 31 1/2"x84 1/2"-120"

cm 90x214,4-304,4 35 1/2"x84 1/2"-120"

cm 100x214,4-304,4 39 1/2"x84 1/2"-120"

### T

Spessore muro

Wall thickness

cm 10 3 7/8"

cm 11 4 3/8"

cm 12,5 4 7/8"

# Tris

## Tris

Porta a battente in tamburato, spessore mm 41. Bordi a sezione arrotondata. Battente laccato lucido poliestere nei colori di serie, laccato opaco e in essenza di rovere (sbiancato, moka, grigio), e radiche su richiesta. Versione Lux con vetro opalino. Stipite in alluminio laccato opaco. Stipite adatto a tutti gli spessori del muro. Feltrino di battuta. Reversibilità del senso di apertura. Cerniere a scomparsa. Montaggio su falsi telai in ferro trattato con antiruggine.

Hollow core hinged door, 41 mm thick. Border sections with rounded edges. Gloss polyester lacquered door panel available in standard range colours, oak (bleached, moka, grey) and briar-root upon request. Lux version features opal glass. Jamb in matte lacquered aluminum. Jamb adapts to any wall thickness. Felt protector. Reversible opening direction. Concealed hinges. Mounted on antirust metal subframe.

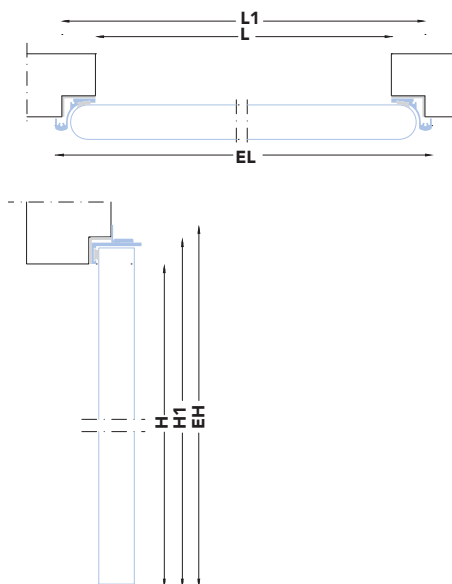

### EL - EH

Ingombro esterno max  
Max external dimensions  
cm 70x214,4-304,4 27 1/2"x84 1/2"-120"  
cm 80x214,4-304,4 31 1/2"x84 1/2"-120"  
cm 90x214,4-304,4 35 1/2"x84 1/2"-120"  
cm 100x214,4-304,4 39 1/2"x84 1/2"-120"

### T

Spessore muro  
Wall thickness  
cm 10 3 7/8"  
cm 11 4 3/8"  
cm 12,5 4 7/8"

### L

Larghezza luce netta  
Opening width  
cm 60 23 5/8"  
cm 70 27 1/2"  
cm 80 31 1/2"  
cm 90 35 1/2"

### L1

Larghezza falso telaio  
Subframe width  
cm 68 26 3/4"  
cm 78 30 3/4"  
cm 88 34 5/8"  
cm 98 38 3/4"

### H

Altezza luce netta  
Opening height  
cm 210-300 82 5/8"-118 1/4"

### H1

Altezza falso telaio  
Subframe height  
cm 213-303 83 7/8"-119 3/8"

### EL - EH

Ingombro esterno max  
Max external dimensions  
cm 70x214,4-304,4 27 1/2"x84 1/2"-120"  
cm 80x214,4-304,4 31 1/2"x84 1/2"-120"  
cm 90x214,4-304,4 35 1/2"x84 1/2"-120"  
cm 100x214,4-304,4 39 3/8"x84 1/2"-120"

### T

Spessore muro  
Wall thickness  
Tutti gli spessori  
All thickness

# Lcd 87

## Lcd87

Porta a battente in tamburato, spessore mm 41. Bordi a sezione arrotondata. Battente laccato lucido poliestere nei colori di serie, laccato opaco e in essenza di rovere (sbiancato, moka, grigio), e radiche su richiesta. Versione Lux con vetro opalino. Stipite in medium-density e alluminio laccati opaco. Stipite di serie sino a cm 12. Feltrino di battuta. Reversibilità del senso di apertura. Cerniere a scomparsa. Montaggio su falsi telai tradizionali in legno. Disponibile anche in versione scorrevole esterna o a scomparsa.

Hollow core swing door, 41mm thick. Border sections with rounded edges. Polished enamelled polyester door panel available in the range colours, oak (bleached, moka, grey), and briar-root upon request. Lux version features opal glass. Jamb in MDF and aluminum. Variety of jamb sizes up to 12 cm. Felt protector. Reversible opening direction. Concealed hinges. Mounted on traditional wooden subframe. Pocket or external sliding version also available.

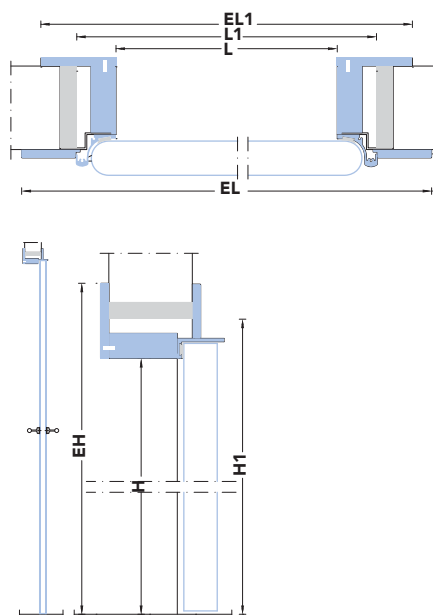

### L

Larghezza luce netta

Opening width

cm 60 23 5/8"

cm 70 27 1/2"

cm 80 31 1/2"

cm 90 35 1/2"

### L1

Larghezza falso telaio

Subframe width

cm 70 27

cm 80 30 7/8"

cm 90 34 7/8"

cm 100 39 3/8"

### H

Altezza luce netta

Opening height

cm 210-300 82 5/8"-118 1/4"

### H1

Altezza falso telaio

Subframe height

cm 215-305 84 1/2"-120 1/8"

### EL1 - EH

Dimensione esterna

External dimensions

cm 78x219-309 30 3/4"x86 1/4"-121" 3/4"

cm 88x219-309 34 5/8"x86 1/4"-121" 3/4"

cm 98x219-309 38 5/8"x86 1/4"-121" 3/4"

cm 108x219-309 38 5/8"x86 1/4"-121" 3/4"

### EL

Ingombro esterno max

Max external dimensions

cm 82,5 32 1/2"

cm 92,5 36 3/8"

cm 102,5 40 3/8"

cm 112,5 44 3/8"



## Maniglie / Door handles

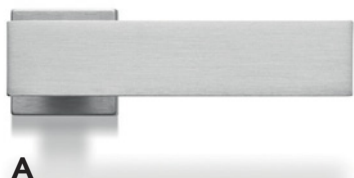

**A**



**B**



**A1**



**A2**



**B1**



**B2**



**A3**



**A4**



**B3**



**B4**

**A**  
Maniglia Push&Pull  
nichel satinato,  
*Push&Pull handle  
satin nichel*

**B**  
Maniglia Lualdi  
cromo satinato,  
*Lualdi handle  
satin chrome*

**A1 - A2**  
Nottolino Push&Pull  
nichel satinato,  
*Privacy lock Push&Pull  
satin nichel*

**B1 - B2**  
Nottolino Lualdi  
cromo satinato,  
*Privacy lock Lualdi  
satin chrome*

**A3**  
Bocchetta yale,  
*Yale escutcheon*

**A4**  
Bocchetta patent,  
*Patent escutcheon*

**B3**  
Bocchetta yale,  
*Yale escutcheon*

**B4**  
Bocchetta patent,  
*Patent escutcheon*

## Maniglie / Door handles



**C**



**D**



**C1**



**C2**



**D1**



**D2**



**C3**



**C4**



**D3**



**D4**

**C**  
Maniglia Martina  
cromo satinato,  
Martina handle  
satin chrome

**D**  
Maniglia Outline  
nichel satinato,  
Outline handle  
satin nichel

**C1 - C2**  
Nottolino cromo satinato,  
privacy lock satin chrome

**D1 - D2**  
Nottolino nichel satinato,  
Privacy lock satin nichel

**C3**  
Bocchetta yale,  
Yale escutcheon

**C4**  
Bocchetta patent,  
Patent escutcheon

**D3**  
Bocchetta yale,  
Yale escutcheon

**D4**  
Bocchetta patent,  
Patent escutcheon

## Maniglia Pomm / Pomm handle



**A**



**B**



**C**



**D**



**E**

**A**  
Grigio alluminio  
*Aluminium grey*

**B**  
Nero opaco  
*Matt black*

**C**  
Rovere naturale  
*Natural oak*

**D**  
Rovere moka  
*Moka oak*

**E**  
Bianco opaco  
*Matt white*

## Maniglie per porte scorrevoli / Handles for sliding doors



**SA**



**SB**

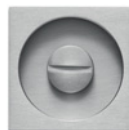

**SC**



**SD**



**S1**



**S2**



**S3**



**S4**

**SA**  
Maniglia ad incasso  
nichel satinato  
*Flush handle  
satin nichel*

**SB - SC**  
Nottolino nichel satinato  
*Privacy lock satin nichel*

**S1**  
Maniglia ad incasso  
cromo satinato  
*Flush handle  
satin chrome*

**S2 - S3**  
Nottolino cromo satinato  
*Privacy lock satin chrome*

**S4**  
Ditale di trascinamento  
*Flush finger pull*

## Colori laccato opaco / Matte lacquer finish



**Bianco Gesso** Chalk White



**Pergamena** Pergamyn



**Grigio Calce** Lime Grey



**Grigio Tortora** Dove Grey



**Grigio Ferro** Iron Grey



**Rosso Ferrari** Ferrari Red

## Colori laccato lucido / Gloss lacquer finish

**Bianco Gesso** Chalk White

**Pergamena** Pergamyn

**Grigio Calce** Lime Grey

**Grigio Tortora** Dove Grey

**Grigio Ferro** Iron Grey

**Rosso Ferrari** Ferrari Red

## Vetri / Glass



**Trasparente** Transparent



**Opalino** Opaline



**Grigio trasparente** Transparent Grey



**Grigio opalino** Opaline Grey



**Grigio riflettente** Reflecting Grey



**Rain Grigio trasparente** Transparent Rain Grey



**Rain Grigio riflettente** Reflecting Rain Grey

## Legni / Woods

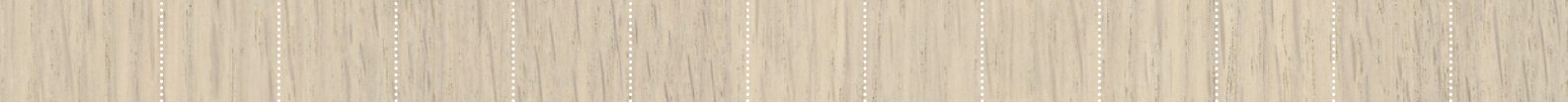

**Rovere Sbiancato** Bleached Oak



**Rovere Grigio** Grey Oak

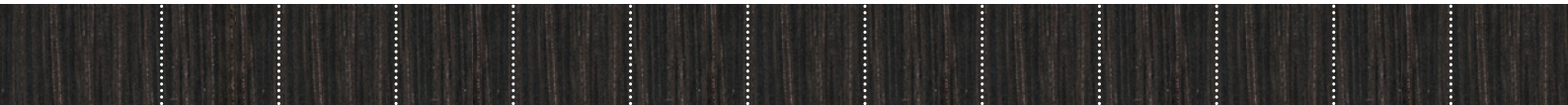

**Rovere Moka** Moka Oak

## Vetri retrolaccati e vetri retrolaccati satinati / Backpainted glasses and backpainted glasses satin



**Bianco Gesso** Chalk White



**Pergamena** Pergamyn



**Grigio Calce** Lime Grey



**Grigio Tortora** Dove Grey



**Grigio Ferro** Iron Grey



**Rosso Ferrari** Ferrari Red



**Lualdi Spa**

Via Kennedy  
20010 Marcallo con Casone (MI)  
**T.** +39 02 9789248  
**F.** +39 02 97289463  
www.lualdi.com  
info@lualdi.com

Showroom

**Milano**

Foro Buonaparte 74  
20121 Milano  
**T.** +39 02 8052445  
**F.** +30 02 8052251  
showroom@lualdi.com

**Miami**

Lualdi Inc.  
2311 North Miami Avenue  
FL 33130  
**T.** +1 305 576 4333  
**F.** +1 305 576 7413

**New York**

110 Greene Street  
Suite 306, New York  
NY 10012  
**T.** +212 334 4544  
**F.** +212 334 4618

a.d. Graph.x

foto Giuseppe Brancato

styling

Carin Scheve

Alessandra Salaris

testi Giovanna Zoboli

traduzioni Richard Peace

**Thanks to:**

Accademia  
Artemide  
Draga Obradovic  
Flos  
Glas Italia  
Lema  
Living Divani  
Porro

pre press, retouching De Pedrini

stampa O.G.M. Spa 2016

I colori e le finiture, le illustrazioni e le descrizioni del presente catalogo sono a titolo indicativo. Lualdi spa si riserva il diritto di apportare, anche senza preavviso, modifiche di carattere tecnico e produttivo.

The colours, finishes, illustrations and descriptions in this catalogue are provided solely by way of example. Lualdi spa reserves the right to make technical and design changes without prior notice.